

Battery, nRF52

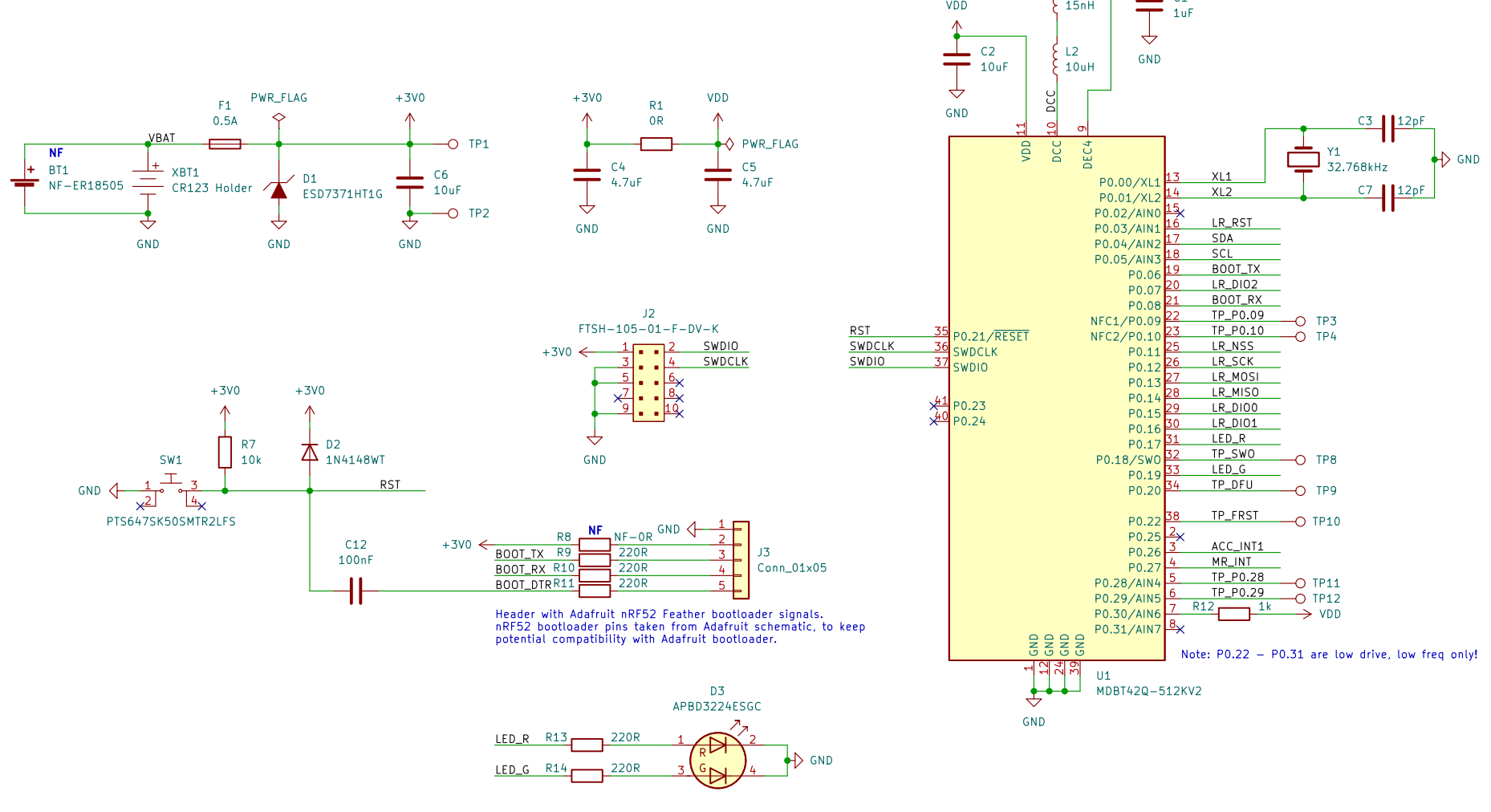

LoRa

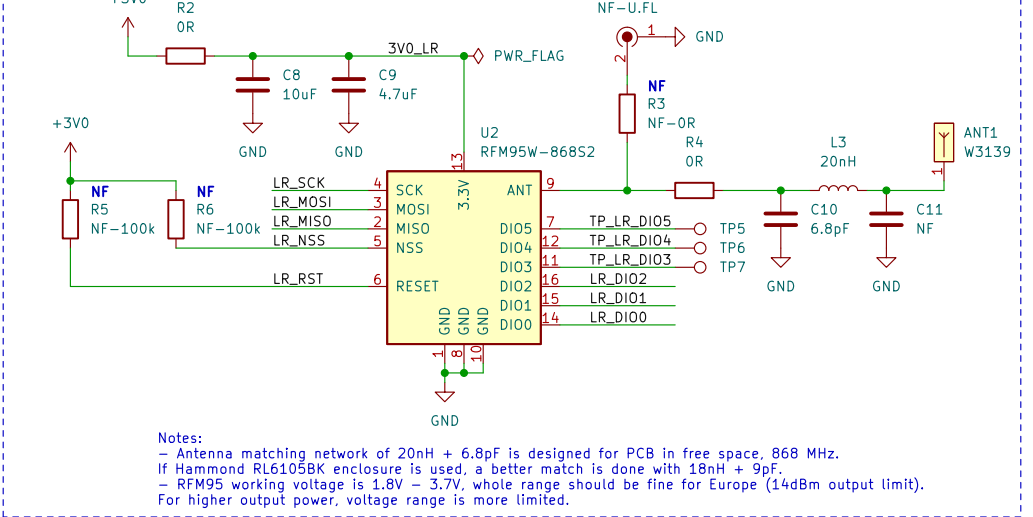

Sensors

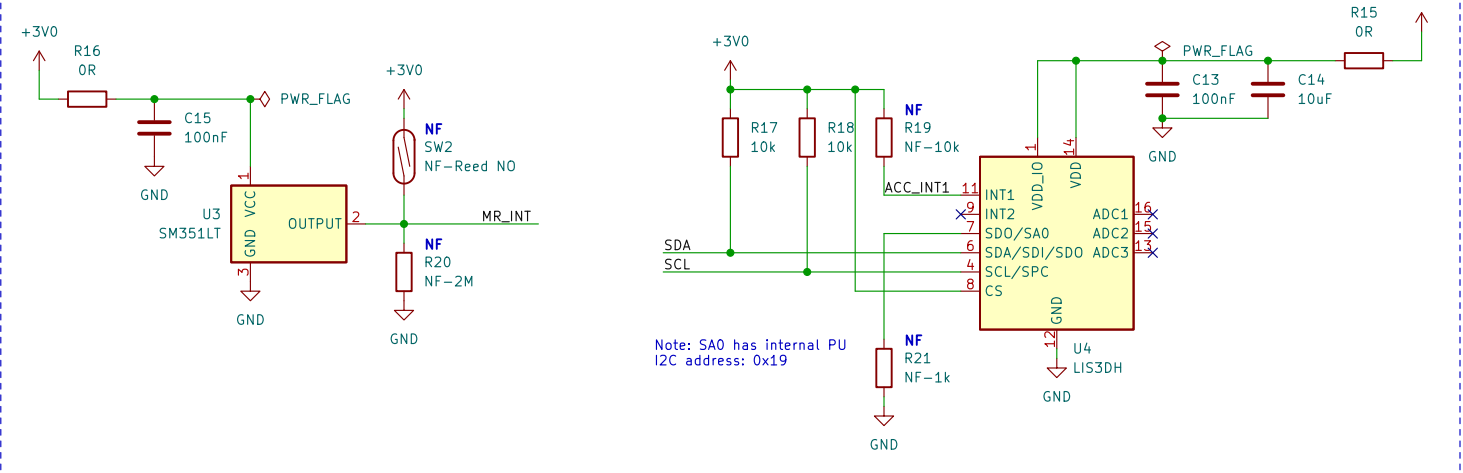

- H1 MountingHole
- H2 MountingHole
- H3 MountingHole
- FID1 Fiducial
- FID2 Fiducial
- FID3 Fiducial
- FID4 Fiducial
- FID5 Fiducial
- FID6 Fiducial

Notes:
 - Open hardware
 - NF = Not Fitted (not assembled by default)
 - PCB fits Hammond RL6105BK and similar

Drawn by: Zvonko Bockaj

Sheet: /
 File: GarageNotifier.kicad_sch

Title: GarageNotifier		
Size: A3	Date: 2022-08-15	Rev: v1.0.0
KiCad E.D.A. kicad (6.0.0)		Id: 1/1